



**SAFE
WORK**

**S
A
F
E** SPOT THE HAZARD
ASSESS THE RISK
FIND A SAFER WAY
EVERYDAY

**EVERYONE'S
RESPONSIBILITY**



Guideline for Industrial Steel Storage Rack

December 2010

Manitoba 

Guideline for Industrial Steel Storage Rack

**Workplace Safety & Health Division
200 – 401 York Avenue
Winnipeg, Manitoba
R3C 0P8**

December 2010



ACKNOWLEDGEMENTS

Some information and illustrations in this guideline are courtesy of the Rack Manufacturers Institute and the Building Seismic Safety Council of the National Institute of Building Sciences. Some instructions and material specifications stem from CSA A344.1/A344.2, *User Guide for Steel Storage Racks/Standard for the Design and Construction of Steel Storage Rack*.

Table of Contents

Introduction.....	3
Manitoba Workplace Safety and Health Regulation Requirements.....	3
Hazard Recognition.....	4
Meeting Steel Storage Rack Requirements	5
Rack Design	5
Types of Racks.....	5
Before Purchasing Steel Storage Racks	6
Products to be Stored.....	6
Materials Handling Equipment.....	6
Building Characteristics Identification.....	6
Rack and Floor Layout.....	7
Plan and Elevation Drawings.....	7
Rack Layouts.....	7
Base Plates	8
Base Plate Design	8
Types of Base Plates	8
Rack Tolerances and Stability.....	9
Vertical Constraints	9
Overturning.....	9
Deflections	8
Bracing	8
Floors	8
Beam Connections	8
Building Connections.....	10
Safe Loading Connections of the Building.....	10
Rating Plates	10
Drive-in' Racks.....	11
Anchoring Application	11
Type of Bolts.....	11
Collision Protection.....	12
Lighting.....	12
Storage Beneath Electrical Lines	12
Inspection and Maintenance	13
Inspection Program	13
Frequency of Inspections	13
Damaged Racks.....	13
Damage Identification and Classification.....	13
Repairs and Corrective Actions	14
Stacking Materials	15
Bricks or Other Masonry Building Materials	15
Structural Steel Materials	15
Bagged or Loose Materials.....	15
Storing Outdoors	15
10 Tips for Rack Safety	15
Illustration of Typical Rack Components	16

INTRODUCTION

This guideline provides general information on the design, installation and use of steel storage racks. Because design and installation requirements may differ widely (ex: custom-engineered or specialized racking), it is important to follow the manufacturer's recommendations.

Workplace Safety and Health Regulation Requirements

The *Workplace Safety and Health Act* and Part 7 of the workplace safety and health regulation (M.R. 217/2006) require employers to ensure that all workplace materials, equipment, machines and tools are stored in a safe manner.

Part 7 of the workplace safety and health regulation states:

Design of racking:

- 7.4(1) An employer must ensure that all racks and frames used to store materials, equipment, machines or tools are:
 - (a) designed, constructed and maintained to support the load placed on them; and
 - (b) placed on firm foundations that can support the load.
- 7.4(2) An employer must ensure that commercially manufactured racks and frames are installed, used and maintained in accordance with the manufacturer's specifications.
- 7.4(3) An employer must ensure that racks that exceed a 3:1 height-to-depth ratio are suitably anchored, externally braced or properly secured to a building or structure.
- 7.4(4) An employer must ensure that all racks and frames used outdoors to store materials, equipment, machines or tools are designed, constructed and maintained to support loads placed on them by wind, wind gusts and other environmental conditions.

HAZARD RECOGNITION

Be aware that the following hazards may exist when using steel storage racks to store materials, equipment, machines and tools at the workplace:

- worker slips and falls from and around the racking during operations and maintenance
- overturning of the rack because of incorrect height-to-depth ratio (of the entire rack)
- failure of the racking structure because of vertical constraints, deflections, beam connections and other stability factors
- collision of moving equipment with the racking system
- overloading of the racking system if amount of product stored exceeds capacity of the racking

Hazards may also exist under the following conditions:

- improper specifications
- poor installation
- no inspection or maintenance
- improper repairs
- unknown capacity

MEETING STEEL STORAGE RACK REQUIREMENTS

Rack Design

Steel storage racks must be designed and put together according to the manufacturer's requirements or the requirements of a professional engineer.

Racks and frames used outdoors to store materials, equipment, machines or tools should be designed, put together and maintained to support loads placed on them including wind, wind gusts and other environmental conditions.

The following Standards apply to the design of steel storage racks:

- *CAN/CSA-S 136, North American Specification for the Design of Cold-Formed Steel Structural Members*
- *CAN/CSA-S16, Limit States Design of Steel Structures*
- *S16S1-05, Supplement #1 to CAN/CSA-S16-01, Limit States Design of Steel Structures* and replacement pages issued June 2003 and December 2003 as Update #1 and Update #2 to *CAN/CSA-S16-01, Limit States Design of Steel Structures* incorporated into the original 2001 standard
- *CAN/CSA A344.1/A344.2 User Guide for Steel Storage Racks/Standard for Design and Construction of Steel Storage Racks*

Types of Racks

Rack types include:

- bulk storage rack
- pallet racks (storage rack)
- cantilever racks
- drum storage racks
- stacking racks
- special purpose racks

BEFORE PURCHASING STEEL STORAGE RACKS

Find out the following information before purchasing steel storage racks for the workplace:

- products to be stored
- material handling equipment to be used
- characteristics of the building in which the storage rack system is to be placed

Products to be stored:

- Get the characteristics of both the product and pallet that will be used to store it.
- Find out if the pallets being used for storage are structurally sound.

Materials handling equipment:

- Learn the manufacturer's specifications for material handling equipment used with the storage system.
- Use the manufacturer's specification for material handling equipment to establish recommendations for operating clearances.

Building characteristics

Facility drawing:

- Examine the appropriate architectural and mechanical drawings, including a plan view and an elevation of the area where the racks will be installed.
- If building drawings are unavailable, take accurate measurements and create a scale drawing of the area proposed for storage rack installation.

Floor loading:

- Building owners or employers must ensure the floor is able to support loads imposed by the storage rack. Examination by a professional engineer may be required.
- It may be necessary to obtain approval from the landlord or building owner before installing storage racks on a slab.
- The storage rack manufacturer or designer must determine storage rack column loads imposed on the floor slab.

RACK AND FLOOR LAYOUT

Create a layout of the proposed racking system and total floor area used before installing steel storage racks at the workplace. This helps ensure adequate clearance and working space for safe movement and storage of materials.

Plan and Elevation Drawings

Plan and elevation drawings should include:

- dimensions for all parts of the rack system
- right-angle stacking and intersecting aisle requirements
- building clearances (including all mechanical systems)
- reference to a specific location within the building

Drawings should identify loads on buildings or structures from the racking system.

Note: The building or structure must be able to support loads imposed on it by the racking system.

Changes to rack configurations may change their capacity to handle loads. Before making any changes, consult a professional engineer or the rack manufacturer.

Rack Layout

Rack layouts should consider interaction with the building and building system, the material handling equipment, productivity issues and damage issues.

Provide adequate clearances for the following:

- between pallets; between pallets and frames (side clearances)
- between pallets and the underside of beams (lift off clearance)
- pallet overhang (loads over pallets and pallets over beams)
- forklift operations
- clearance for lift trucks or other powered mobile equipment to pass each other in the aisles, if applicable
- access to doors

BASE PLATES

All rack columns must be equipped with appropriate **base plates**. Proper base plates provide uniform transfer of the column load to the floor. The rack manufacturer or designer can supply data on the size and pressure exerted under the bearing plates for each type of upright and setup. This will confirm whether the floor can withstand the anticipated load. (Figures 1a and 1b illustrate types of base plates.)

Guidance is provided in *CSA Standard A344.1, User Guide for Steel Storage Racks*.

Base Plate Design

A base plate must provide for anchorage and be designed to support the entire profile of the column placed on it.

The base plate must transfer the column load in a uniform manner to the supporting structure (floor).

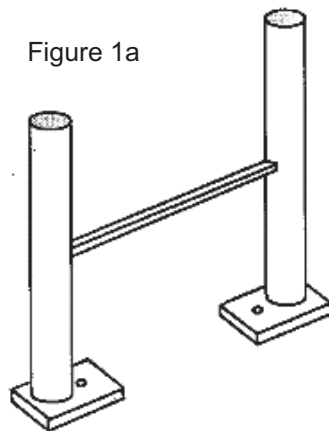

Figure 1a
Bearing plates are placed under each post

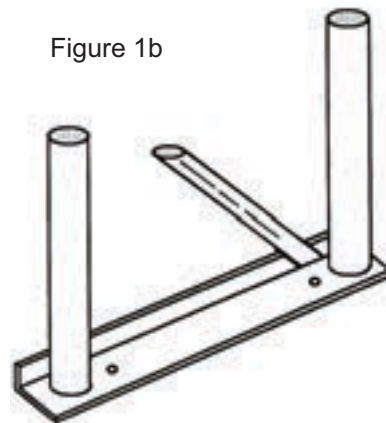

Figure 1b
A continuous bearing plate joining the two posts

Note: The Canadian Standards Association (CSA) does not provide design criteria for floors that support storage racks.

RACK TOLERANCES AND STABILITY

Vertical Constraints

Rack capacity and rating depends on plumb or vertically straight rack installation. Install the vertical parts of the racks according to design specifications. Maximum tolerance is 12.5 mm per 3 m of height (1/2 in. per 10 ft. of height). A rack not installed and maintained plumb is subject to stresses that will reduce capacity and stability.

Figure 2

Overturning

The height-to-depth ratio of the entire rack should not exceed 3:1 measured from the floor to the top of the rack unless the rack is suitably anchored, externally braced or properly secured to the building structure. Placing racks back to back and connecting them will increase their stability. Figure 2 illustrates the height-to-depth ratio.

Height to Depth Ratio: Should not exceed 3 to 1 unless the rack is anchored or properly secured.

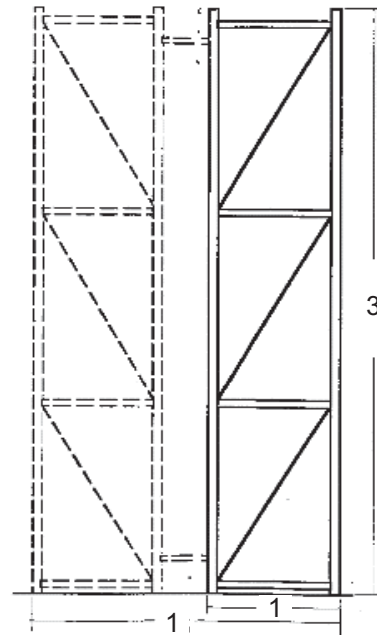

Deflections

At maximum working load, the deflection of rack beams must not exceed 1/180th of the span of the beam. For example, if the span of the beam is 4 m (13.12 ft), the maximum deflection allowed is 22 mm (.87 in).

Bracing

Diagonal bracing of the racking systems depends on design considerations and varies from one racking system to another. Diagonal bracing must ensure the stability of the columns. Review the original design specifications to determine proper structure bracing.

Floors

Racks installed on uneven floors must be levelled. The columns must meet the vertical constraint standards described above and all shelves must be level.

Beam Connections

In addition to design load specifications, beams must have support connections that are capable of withstanding an **upward force** of 4,500 kN (1,011 lbs. of force) per connection, without failure. This protects support connections in the event that a forklift (or other powered mobile equipment) collides with the structure.

Building Connections

Rack connections made to the building must ensure that the loads imposed by the racks do not affect the structural integrity of the building. The **opposite** is true also. The building should not damage the rack. This can occur if the rack attaches to the roof of a building and the roof deflects under a snow or rain load, causing deflection of the rack.

Safe Loading Conditions of the Building

Employers are responsible to ensure that safe loading conditions for a permanent or temporary building or structure (as specified in the *Manitoba Building Code* or the design specifications of a professional engineer), are not exceeded during its construction and, when it is used to store materials, equipment, machines or tools, as specified in Part 7 section 7.2(1) of the workplace safety and health regulation.

Furthermore, Part 7, section 7.2(2) states: "If it appears that the loading conditions specified in subsection (1) may be exceeded when the use of a building or structure is changed, the employer must ensure that the loading conditions respecting the changed use are certified in advance of the change in use as being safe by a professional engineer."

Rating Plates

Maximum load plates must be clearly posted in a visible location at the worksite indicating allowable unit loads (ex: maximum pallet weights, sizes, etc.) and total bay loads for each type of racking. Figure 3 illustrates a sample load plate.

Figure 3

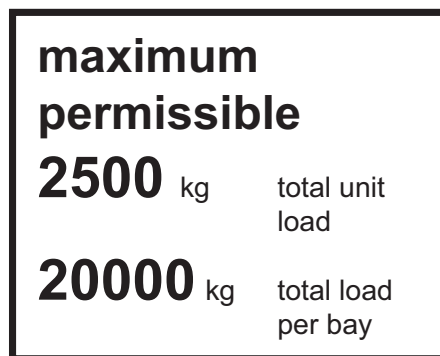

Drive-in Racks

Drive-in and drive-thru rack systems are efficient ways to store large quantities of similar loads by allowing the forklift driver to enter the rack system and place the load on structural rails. A major difference between these two systems is that drive-thru racks can provide first-in/first out (FIFO) storage, while drive-in racks only function as first-in/last out (FILO) systems.

The design of the drive-in and drive-thru racks requires much the same information as for standard pallet racks. Detailed specifications of forklifts used are needed because the rack bay opening and first tier must provide space for the lift truck and the pallet load.

Specific guidelines for this type of rack are as follows:

- Racks without pallet guides – the gap between the inside edges of the opposing rails must not exceed the pallet width minus 25 mm (1 in.). See Figure 4a.
- Racks with pallet guides – the distance between the guide and inside edge of the opposite rail must not exceed the pallet width minus 19 mm (3/4 in.). See Figure 4b.

Both requirements must allow for lateral deflections that may occur under load.

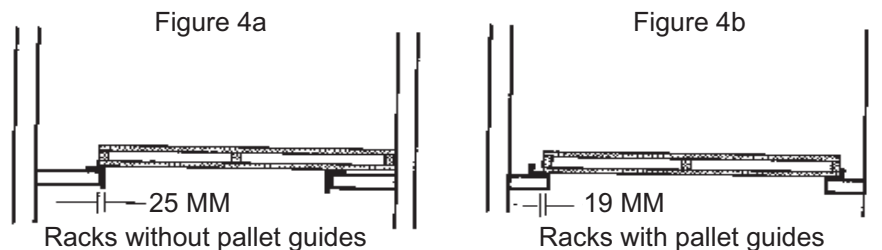

Anchoring Application

Racks must be anchored if the height to depth ratio exceeds 3:1. Drive-in and drive-through racks must be anchored to the floor at all times.

Though it is best that all storage racks are anchored, if racks are stable and the manufacturer can show that the friction forces between the bearing plates and the floor are enough to resist **horizontal movement**, anchoring is not required.

Type of Bolts

Anchor bolts must withstand forces caused by vertical and horizontal loading. Structurally rated bolts should be used for anchoring. Expandable bolts attaching bearing plates to concrete should be rated to secure storage racks loaded at maximum capacity safely.

Collision Protection

It is difficult to design a rack to be collision-proof, but suitable protection can be provided. Serious structural damage usually occurs when the bottom portions of exposed rack columns are struck by forklifts or other moving equipment.

Two ways recommended to protect against collision:

1. Reinforce the exposed column. See Figure 5.
2. Connect a post or guardrail to the floor to absorb any impact. See Figure 6.

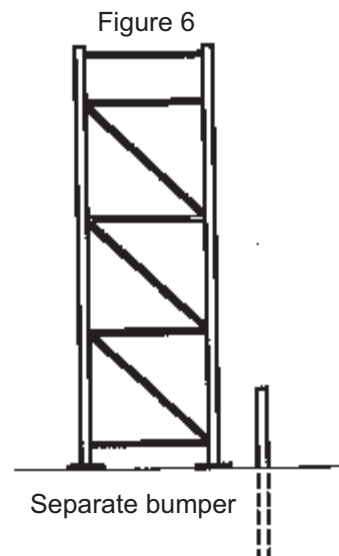
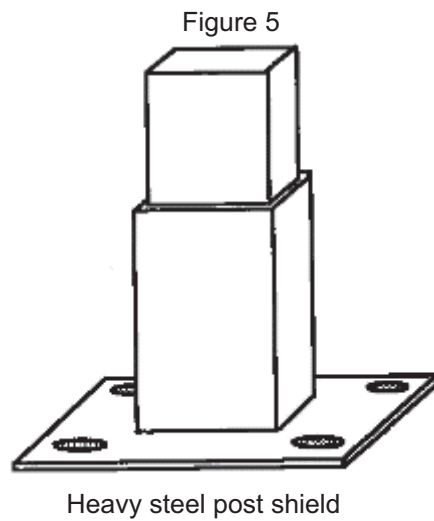

Lighting

Proper lighting is important. It can make rack entry and material placement easier and help reduce rack damage.

Storage Beneath Electrical Lines

Part 7 Section 7.3 of the workplace safety and health regulation directs employers to obtain written approval from the electrical authority before storing machinery, materials or equipment beneath an outdoor overhead electrical line.

INSPECTION AND MAINTENANCE

Inspection Program

Owners or employers using steel storage racks in the workplace must ensure a program is in place to inspect them regularly. The person conducting inspections should be provided with a current layout, elevation drawings and manufacturer's instructions for the storage racks.

The inspection must identify any variance from the layout and elevation drawings provided, as well as any structural damage and missing or moved storage rack parts.

The inspection must also make note of poor operating practices, if they are observed in connection with storage racks.

A record of each inspection must be kept at the workplace and a copy must be provided to the safety and health committee or representative at the workplace. Inspection programs will be specific to each workplace and based on the size and use of each storage rack installation.

Frequency of Inspection

Experienced personnel should visually inspect heavily used racks daily. All connections must be inspected to ensure that bolts and other structural pieces are not loose or damaged.

Damaged Racks

Ninety percent of rack damage occurs between the floor and the first horizontal beam. Repairs will vary by rack system. Always consult the manufacturer about how to repair damaged racks and components properly.

Conditions that contribute to rack damage:

- overloading by placing too much material on the rack
- using minimum rather than recommended material handling equipment clearances
- person placing load on the rack is inexperienced
- use of certain types of material handling equipment (ex: forklifts)

Damage Identification and Classification

Rack damage should be identified and classified as severe structural damage or moderate damage.

- severe structural damage – refers to parts that are buckled or severely bent and must be replaced.
- moderate damage – refers to columns that are dented, slightly skewed, etc. They may be repaired by adding braces or splices strong enough to carry the intended load.

If a part of the rack is determined unsafe, the part must be clearly identified by marking or tagging.

Any loads in the area of the unsafe part must be immediately removed from the rack and not reloaded until repairs are complete.

Repairs and Corrective Actions

Minor damage to storage racks must be repaired or replaced immediately. If storage racks receive severe or structural damage, repair work must be approved by a professional engineer.

Repetitive damage, particularly to the lower section of frame columns, suggests a need for post guards, changes to the rack layout or changes to operating practices at the workplace.

STACKING MATERIALS

Store materials on level and stable platforms. The height of the material pile must be determined (according to the type of material) to ensure that it does not destabilize the structure.

Bricks or Other Masonry Building Materials

Do not pile bricks or other masonry building materials more than 2 m (6.6 ft.) high, unless the pile tapers by one-half block per tier above the 2 m (6.6 ft.) level.

Structural Steel Materials

Stack structural steel materials (including poles, pipes or bar stock) in racks or frames, or restrain them to prevent movement.

Bagged or Loose Materials

Support bagged or loose materials to prevent movement.

Storing Outdoors

Consider the effects of wind, wind gusts, extreme temperatures and other environmental conditions when determining the method of stacking and storing material outdoors.

10 Tips for Rack Safety

- a. When buying storage racks, ensure durability and protection features are built into the design.
- b. Ensure the structural integrity of the walls and floors before installing your storage rack.
- c. Install storage racks according to the manufacturer's specifications.
- d. Make sure the aisles where the storage rack will be loaded are wide enough to accommodate the lift truck's turning radius easily.
- e. Conduct regular inspections, maintenance and repairs of storage racks.
- f. Look for scratched paint, dents and bowed out components.
- g. Ensure you use your storage rack according to the manufacturer's specifications.
- h. Train workers to load storage racks properly.
- i. Conduct rack safety awareness training for all employees, and encourage them to report bangs and dents of racks.
- j. Retrain lift truck or power mobile equipment drivers as required.

Source: Chuck Leon, IAPA Health and Safety Training Specialist/Consultant; prepared for IAPA's course, Inspecting and Maintaining Steel Storage Racks.

Figure 7

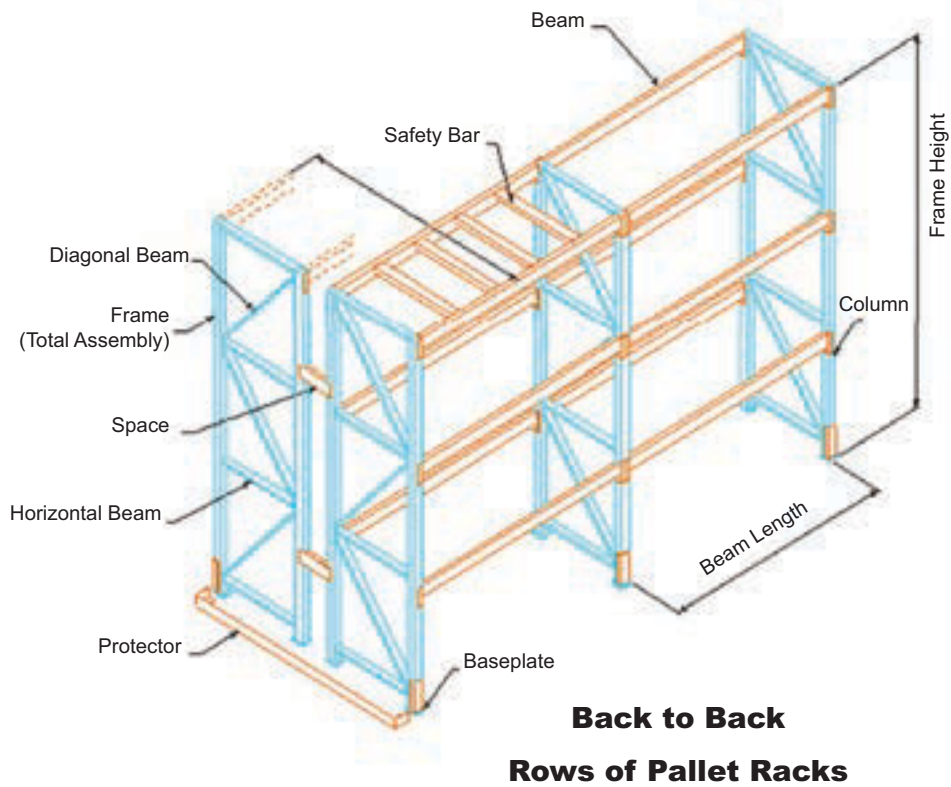

Typical storage rack configuration

Illustration from FEMA 460, *Seismic Consideration For Steel Storage Racks Located in Areas Accessible to the Public*, developed for the Federal Emergency Management Agency by the Building Seismic Safety Council of the National Institute of Building Sciences.

